

dickinson
since 1932

NEWPORT - P12000

Propane Fireplace/Heater

MODEL 00-NEW-P12000

INSTALLATION AND OPERATING MANUAL

Manufactured by:

Dickinson Marine (1997) Ltd,
407-204 Cayer Street,
Coquitlam, British Columbia,
Canada V3K 5B1

PACKING LIST

PART NO

00-NEW-P1200 - NEWPORT PROPANE FIREPLACE/HEATER

- Including
- 28" approx (70cm) Direct Vent Pipe Kit (approx.)
1.5 ins (37.5mm) Inner S/S Pipe
2.5 ins (62.5mm) Outer S/S Pipe
4 spacer springs installed inside pipe
 - S/S Double - Direct Vent - Flue Cap - Sealing Gasket - Inner Dress Ring - mounting screws
 - S/S Back Mounting Plate (attached to heater)

OPTIONAL ACCESSORIES AVAILABLE

PART NO

- 19-000 - 28 ins (70cm) Direct Vent Pipe Extension Kit (approx.)including coupling
- 19-010 - 120VAC to 12VDC Shore Power Converter. (power jack installed on heater)
- 19-151 - Low pressure regulator only
- 19-150 - Low pressure regulator and mounting kit (For use when there is no onboard propane system - for use with propane bottles)
- 19-100-10 - 10ft (3 m) CGA/AGA propane hose
- 19-100-20 - 20ft (6 m) CGA/AGA propane hose

Contact your local dealer for pricing of the above accessories.

THIS IS A QUALITY DICKINSON PRODUCT.

Should you discover any shortages or defective parts please contact your dealer immediately and the problem will be rectified.

SPECIFICATIONS - P12000

Model	-	NEWPORT PROPANE FIREPLACE/HEATER
Type	-	DIRECT VENT
Ignition	-	MANUAL
Fuel	-	LPG (Propane/Butane) Low Pressure - 11 ins water column
Fuel Consumption	-	1lb bottle - Low 5.5 hrs : High 3.9 hrs 20lb bottle - Low 110 hrs : High 78 hrs
Fuel Line	-	3/8 ins copper or approved hose - 3/8 ins flare fitting
Heat Rating - Fan Off	-	Low 4000BTU/h - 920kcal/h (1080w/h) High 5500BTU/h - 1289kcal/h (1485w/h)
Heat Rating - Fan On	-	Low 8000BTU/h - 1840kcal/h (2160w/h) High 11500BTU/h - 2645kcal/h (3105w/h)
Heater Dimensions	-	Height - 16 ins (40cm) Width - 10 ins (21.25cm) Depth - 7.25 ins (18.13cm) Mounted Depth - 8 ins (20cm)
Weight	-	20 lbs (9.09 kg)
Blower Fan Power Source	-	12VDC - Power jack for 120VAC to 12VDC installed. (500ma 2.1mm Centre Positive) (Dickinson Part No. 19-010)
Power Consumption	-	.17amp
S/S Flue Pipe - Flexible	-	Inner nominal - 1.5 ins (37.5mm) diameter. Outer nominal - 2.5 ins (62.5mm) diameter
S/S Flue Pipe - Flexible	-	Minimum Operating Length - 24ins (60cm) Maximum Operating Length - 60 ins (1.5m)
Double Flue Outlet	-	Height above deck - 4.5 ins (11.25cm) Deck Flange diameter - 6 ins (15cm) Deck Mount hole size - Min 3 ins (7.5cm)

NEWPORT PROPANE FIREPLACE

MODEL NO. 00-NEW-P12000

INDEX

	Page
INSTALLATION	1
Location.....	1
Mounting.....	2
Direct Vent Thru Fitting and Cap.....	2
Installation Diagram.....	2
Installation Procedure.....	3
Gas Supply Hook-Up.....	4
Typical ; LPG On-Board System - Diagram...	4
Blower Fan - Electrical.....	5
OPERATION	5
Lighting.....	5
Burning Characteristics.....	6
Safety Features.....	6
Problems... ..	6
WARRANTY	7

FOR YOUR SAFETY

Do not store or use gasoline or other flammable vapors and liquids in the vicinity of this or any other appliance.

WHAT TO DO IF YOU SMELL GAS

Do not try to light any appliance.
Do not touch any electrical switch: do not use any phone in your building.
Immediately call your gas supplier from a neighbor's phone. Follow the gas supplier's instructions.
If you cannot reach your gas supplier call the fire department.

WARNING

Improper installation, adjustment, alteration, service or maintenance can cause injury or property damage. Refer to this manual. For assistance or additional information consult a qualified installer, service agency or the gas supplier.

INSTALLATION

LOCATION

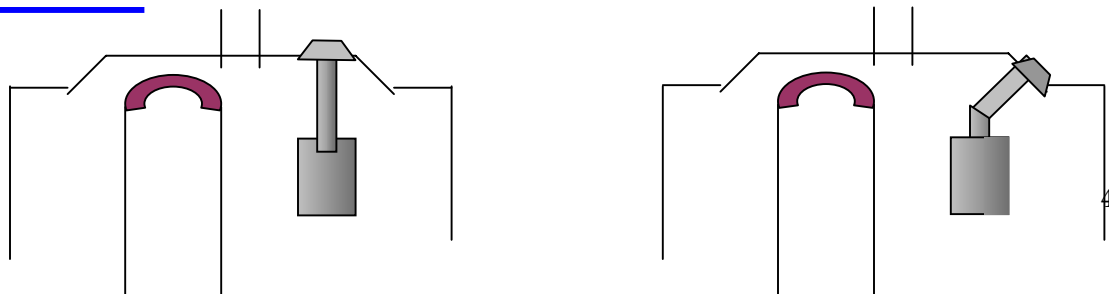

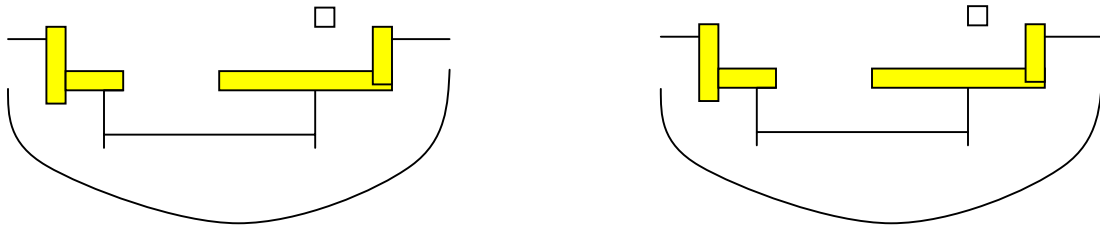

LOCATE the heater where it will maximize the radiant heating capability. The NEWPORT PROPANE HEATER is equipped with a manually operated blower fan that will blow hot air from the top of the heater down onto the floor. This increases heating efficiency and provides good circulation of hot air.

LOCATE so that the front and sides of the heater are at least 3 ins (75 mm) from combustible surfaces.

LOCATE to provide easy installation of the flue and external flue cap. The mounting flange of the thru fitting and cap requires an area of at least 6" (15cm).

LOCATE keeping in mind that the top cap gets hot and that the hot products of combustion are being emitted when the heater is operating.

NOTE : The direct vent chimney is flexible and can be bent to provide any angle of offset. The minimum length recommended is 2 ft (60 cm) and the maximum length 5 ft (1.5m). The heater will work with more or less chimney length however this may cause a slight variance in the burning characteristics. Installing the thru-fitting and flue cap at an angle of no more than 45 degree is not a problem.

We do not recommend installing the thru-fitting and flue cap with a **horizontal exit**. If there is no other option the heater will work satisfactorily when the full length of the exhaust pipe supplied 30 ins (75 cm) is used to achieve the 90 degree angle. Again keep in mind that the top cap gets hot and that the hot products of combustion are being emitted when the heater is operating.

LOCATE for easy, safe access to the source of propane gas.

MOUNTING

Secure the heater mounting plate directly onto the mounting surface. No additional insulation is required. No screws or bolts are provided, as each installation will have different securing requirements.

DIRECT VENT STAINLESS STEEL FLEX PIPE

Four springs are installed between the inside and outside pipe to ensure that an even air space is provided. **IT IS IMPORTANT THAT TWO SPRINGS BE LOCATED AT ANY BEND IN ORDER TO PREVENT THE PIPES FROM TOUCHING.** The length of pipe supplied is approximately 28" (70cm). The pipe can be stretched to provide several additional inches. Bending the pipe will cause the pipe to stretch. The pipe can be cut with a fine hacksaw blade to the required length. **Tape the end of the pipe while cutting to prevent the pipe from unraveling and the diameter increasing.**

The pipe is lubricated during the manufacture process. **This lubricant will burn off on the first firing of the heater.**

Additional 28" (70cm) lengths of pipe are sold as an option (Part No. 19-000). This pipe can be cut with a fine hacksaw blade to the required length. A coupling fitting is provided with the optional length.

DIRECT VENT THRU-FITTING AND CAP

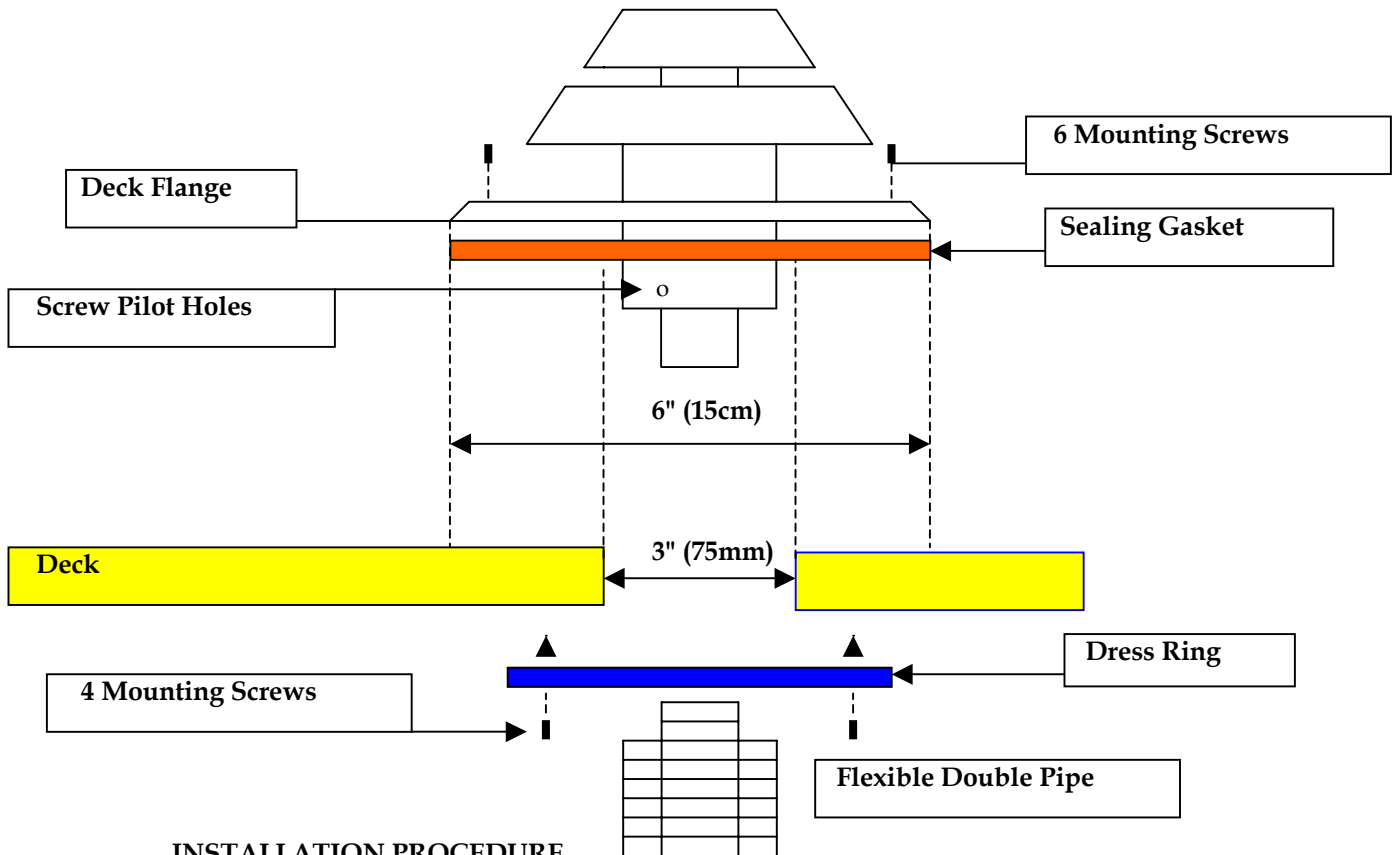

INSTALLATION PROCEDURE

- Step - 1** Cut a 3" hole through the deck, ceiling or wall.
- Step - 2** Make sure the sealing gasket is installed under the above deck-flange before screwing down the fitting. Rotate the fitting to position the pipe seam, inside the boat, so that it is not visible. Holding the deck flange firmly in position secure with the 6 S/S screws supplied.
- Step - 3** Attach the dress ring on the inside, and on the underside, of the fitting with the 4 S/S screws supplied. Make sure that the opening lines up with the underside of the thru-deck or the pipe will not fit correctly.
- Step - 4** Install the flexible pipe on the heater.
- Step - 5** Make whatever bends are necessary in the flexible pipe and push into the thru-fitting.
- Step - 6** Secure the heater in position by attaching the back mounting plate.
- Step - 7** Using the screw pilot holes in the outer pipe of the thru-fitting drill two 1/8"

DIRECT VENT FITTING

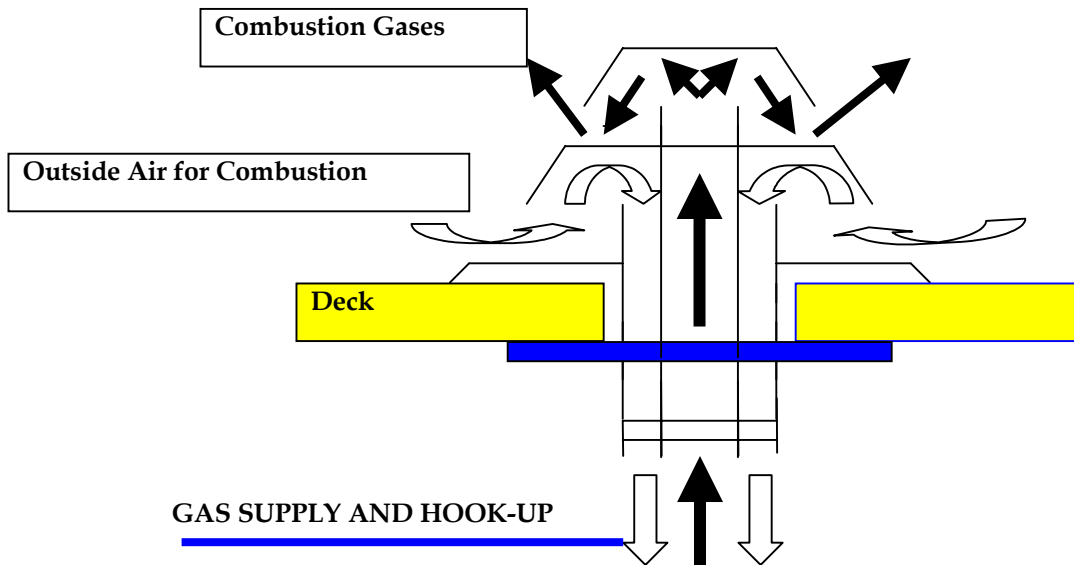

GAS SUPPLY AND HOOK-UP

THE HEATER OPERATES ONLY ON LOW PRESSURE LPG GAS (11" w/c)

If there is a propane fuel system installed a separate supply line must be supplied for the heater. This line must be equipped with a low-pressure regulator (Dickinson Part No. 19-151)

Connect to the 3/8" flare connector of the heater with copper or an approved hose. During this procedure some particles may get into the fuel line. These could block or restrict the small heater orifice. **BLOW OUT FUEL LINE PRIOR TO ATTACHING TO THE PROPANE SUPPLY AND THE HEATER.**

Disposable Propane Bottle

It is necessary to install a pressure regulator for gas supplied from a propane bottle. For this type of installation we suggest using a Dickinson Low Pressure Kit (Part No. 19-150) This Kit includes a pressure regulator (11 ins W/C) and a mounting kit. The kit must be mounted outside. A Dickinson AGA/CGA propane hose can be used to connect this Kit to the heater. These are available in 10 ft (3m) (Part No. 19-100-10) or 20 ft (6m)(Part No. 19-100-20)

**AFTER GAS HOOK-UP AND BEFORE LIGHTING THE HEATER
TEST ALL GAS AND CONNECTIONS FOR LEAKS WITH A
SOAP SOLUTION**

TYPICAL LPG ON-BOARD SYSTEM

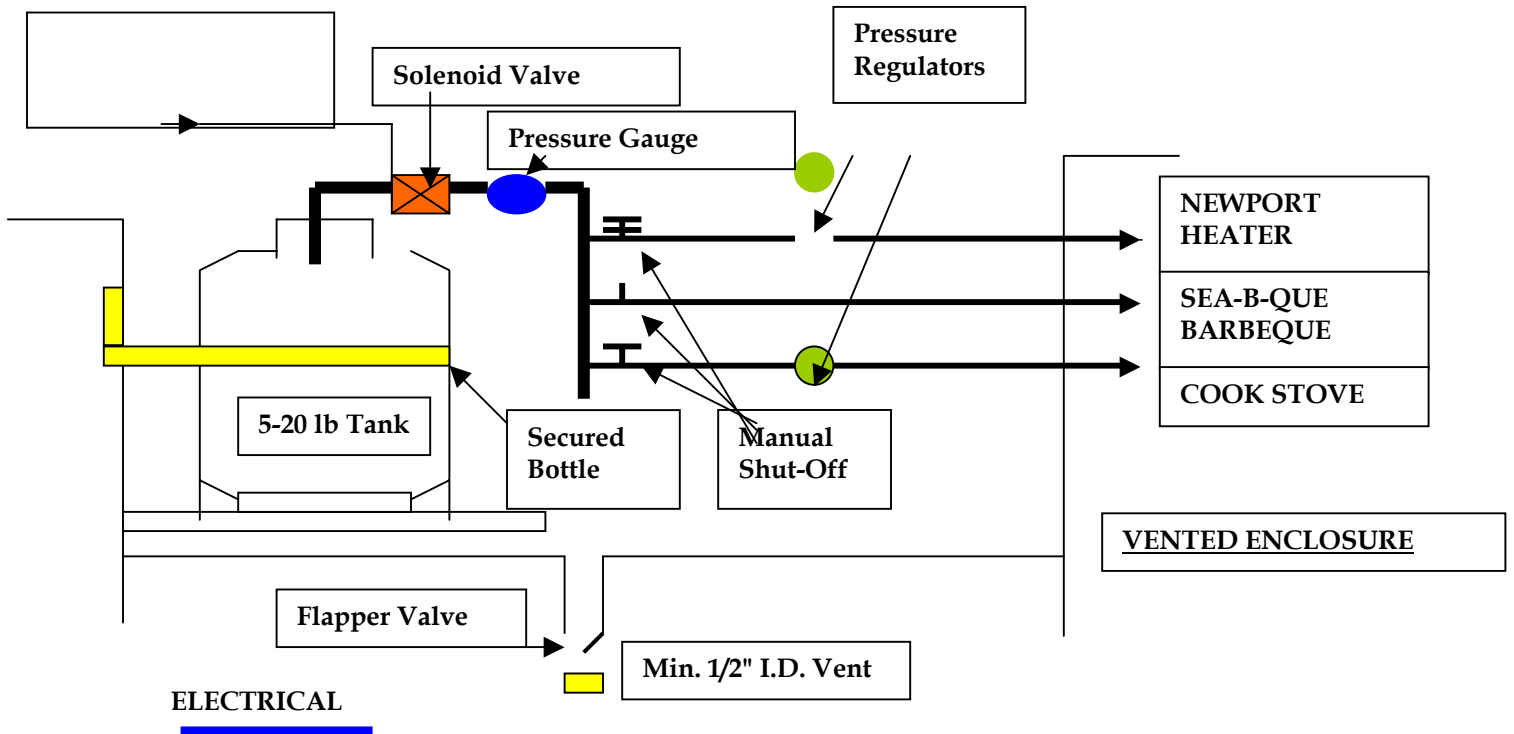

ELECTRICAL

The blower fan is 12VDC and the power supply must be brought to the wire connectors of the fan ON/OFF switch through the grommet installed.

A **power converter jack** (centre positive) from 120VAC to 12VDC is installed on the heater. A 120VAC to 12DC power converter (Dickinson Part No. 19-010) is used to operate the fan with 120VAC power. Plugged in to the jack the heater will use the 120VAC-power source. Removed from the jack automatically switches the fan control to 12VDC.

Use of the blower fan is optional but greatly enhances heat output and hot air circulation.

OPERATION

LIGHTING

TEST ALL GAS LINES AND CONNECTIONS FOR LEAKS WITH SOAP SOLUTION.

NOTE : ONLY ON FIRST LIGHTING the lubricating oil on the stainless steel pipe will produce smoke and burn off. THIS IS NORMAL. We suggest that windows and hatches be opened. Smoke from the inside pipe will be emitted outside, through the flue cap.

- 1) Open heater door
- 2) Turn **GAS** knob to **LOW**
- 3) Depress knob and light burner manually.
- 4) Keep knob depressed for 15/20 seconds. **CLOSE HEATER DOOR.** Release knob and flame will remain lit.
(Leaving the heater door open after ignition could cause flame to go out when the knob is released)
- 6) **LOW** or **HIGH** may now be selected.

BURNING CHARACTERISTICS

On each lighting the heater flame will create a roaring sound for about 5 minutes until the direct draft system stabilizes and reaches operating temperature. Initially the flame is extremely blue and vibrant. After a short period of time the flame will increase in size and become less vibrant and more yellow. This will create more of a fireplace effect.

Selecting Low or High settings will only make a small difference to the height of the flame. However, at high the heater is burning 40% more fuel than at low and producing 40% more heat. At the high setting the baffle at the top of the combustion chamber will glow red. This is normal and maximizes the efficiency of the heater.

Installations using an extremely short chimney length i.e. less than 24" (60cm) may experience carboning at the high fire setting. Also, short chimneys installed with a horizontal external outlet may experience the same carboning at high fire.

This can be solved either by operating heater only at low or by operating the blower fan. Running the blower fan cools the top of the heater and the chimney and therefore improves the direct draft.

SAFETY FEATURES

Your heater is equipped with a CGA/AGA approved safety gas valve. Should the flame be extinguished the gas will be shut-off.

Manual ignition involves lighting the heater with the door open and therefore avoids any initial build up of unburned gas.

The heater door is tension mounted and spring loaded to completely seal the combustion chamber.

THE INSTALLATION OF A LPG DETECTOR IS RECOMMENDED FOR ALL LPG APPLIANCES.

PROBLEM?

No gas to burner on lighting
Fire does not stay lit when
knob is released

Any other

SOLUTION!

Check that knob is exactly at 9 o'clock when depressed
Depress knob, light burner and CLOSE
COMBUSTION CHAMBER DOOR before releasing
knob
Check that the door is seal is good
Contact dickinson 1 800 659 9768
Email - dmarine@dickinsonmarine.com

LIMITED WARRANTY

WARRANTY PROVISIONS : dickinson warrants this product to be free of defects in workmanship and materials for a period of one year. This warranty is limited to claims submitted in writing within a one-year period following the date of purchase. If any part of your new product fails because of a manufacturing defect within the warranty period dickinson offers to replace said parts free of charge provided, however, that such parts have not been improperly repaired, altered or tampered with or subjected to misuse, abuse or exposed to corrosive conditions. This warranty however, is limited to certain exclusions, time limits and exceptions as listed below. Read these limitations and exclusions carefully.

TIME LIMIT : This warranty is given too and covers only the original purchaser. Coverage terminates one year from the date of purchase for parts replacement.

EXCLUSIONS : This warranty does not cover or include : (a) Any normal deterioration of the product and appearance of items due to wear and/or exposure; (b) any guarantees, promises, representations, warranties or service agreements given or made by an authorized distributor or other person selling this product, other than those specifically stated herein; (c) any damage or reasonable and necessary maintenance, misuse or abuse of the equipment, or exposure to corrosive conditions. This warranty is conditional upon normal use, reasonable and necessary maintenance and service of your product, and written notice being given promptly upon Buyer's discovery of a warranty claim, pursuant to paragraph 6 below. Reasonable and necessary maintenance is maintenance which you are expected to do yourself or have done for you. It is maintenance, which is necessary to keep your product performing its intended function and operating at a reasonable level of performance.

DAMAGE LIMITATIONS WARRANTY : IN NO EVENT SHALL dickinson BE LIABLE FOR ANY INCIDENTAL OR CONSEQUENTIAL DAMAGES, INCLUDING (BUT NOT LIMITED TO) LOSS OF USE OF THE PRODUCT, LOSS OF TIME, INCONVENIENCE, EXPENSES OR TRAVEL, LODGING TRANSPORTATION CHARGES, LOSS BY DAMAGE TO PERSONAL PROPERTY OR LOSS OF INCOME, PROFITS OR REVENUE.

ORAL OR IMPLIED WARRANTY LIMITATIONS : The foregoing warranty is exclusive and in lieu of all other warranties, written or oral, expressed or implied, including but not limited to any warranty or merchantability or fitness for a particular purpose.

TRANSFER LIMITATIONS : This warranty is not assignable or transferable. It covers only the original purchaser.

CLAIM PROCEDURE : In the event of a defect, problem or that a breach of this warranty is discovered, in order to protect any warranty rights you must promptly notify dickinson. Give name and address, model name, location of unit, description of problem and where you can be reached during business hours.

RESERVED RIGHT TO CHANGE : dickinson reserves the right to make changes or improvements to products in the future without imposing on itself any obligations to install the same improvements in the products it has previously manufactured.

SECOND OR SUBSEQUENT OWNER : dickinson does not give any warranty to secondary or subsequent purchasers, and it disclaims all implied warranties to such owners.

INSPECTION : To assist you in avoiding problems with your product and to validate this warranty you are required to do the following : (a) read the warranty; (b) inspect the product. Do not accept delivery until you have examined the product with your supplier; (c) ask questions about anything you do not understand concerning the product.

OWNER REGISTRATION : Fills out the **WARRANTY CARD** within 30 days from the date of delivery.

WARRANTY : RETURN OF THE CARD IS CONDITION PRECEDENT TO WARRANTY, COVERAGE AND PERFORMANCE. IF YOU DO NOT FILL OUT AND MAIL THE CARD AS DIRECTED YOU WILL NOT HAVE A WARRANTY.

LEGAL RIGHTS : This warranty gives you specific legal rights and you may also have other rights, which may vary within different government jurisdictions.