

Round Surface SKYscreen -

Technical Sheet 26

General Arrangement Drawing

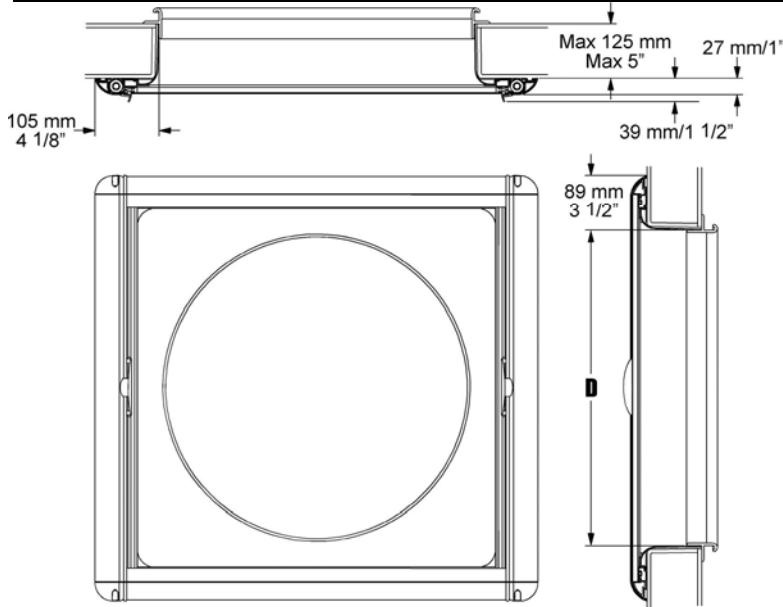

See Technical Sheet 24 for rectangular hatches

Description

- SKYscreen cassette of black out blind and flyscreen incorporating an ultra violet stabilised ABS moulding forming the interface between the underside of the round hatch and square blind in the interior

Install Design Points

- Complete assembly ready to install,
- Resolves all thru-deck engineering
- Operation by magnetic closure on crossbars for ease of use.
- Suitable for concealed installation by recessing unit and building headlining panel over
- Ability to create individual look for each builder – see concealed installation
- Minimum space requirement

How to Order

- **Size 1:** internal diameter 518mm (20³/₈" overall 704mm by 731mm (27³/₄" by 28³/₄") (to suit Lewmar 22, Bomar 1139, Trend and Gebo round). Order as SFSSRD-518-SLR-130
- **Size 2:** internal diameter 420mm (16"), overall 531mm by 548mm (20⁷/₈" by 21⁵/₈"). Order as SFSSRD-405-SLR-130
- **Size 3:** internal diameter 305mm (12"), overall 421mm by 448mm (16⁵/₈" by 17⁵/₈"). Order as SFSSRD-305-SLR-130
- Standard height of liner is 125mm (5"), can be trimmed for contract orders

Technical Specification

- Polymer extrusion, ultraviolet stabilised
- Frame colour Off White RAL 9010 or Beige RAL 1013
- Matching colour mouldings UV Acetal
- Glass fibre PVC coated flyscreen mesh – white
- Off-white polyester blackout water repellent fabric
- Moulding colour Off White RAL 9010 or Beige RAL 1013
- UV stabilised ABS trim moulding

Oceanair Marine Limited Chichester PO20 0AY England

t: +44 (0)1243 606909 f: +44 (0)1243 608300 www.oceanair.co.uk e: TechSupport@oceanair.co.uk