

# Surface SKYscreen- Rectangular Hatches

# Technical Sheet 24

## General Arrangement Drawing

### Version 2

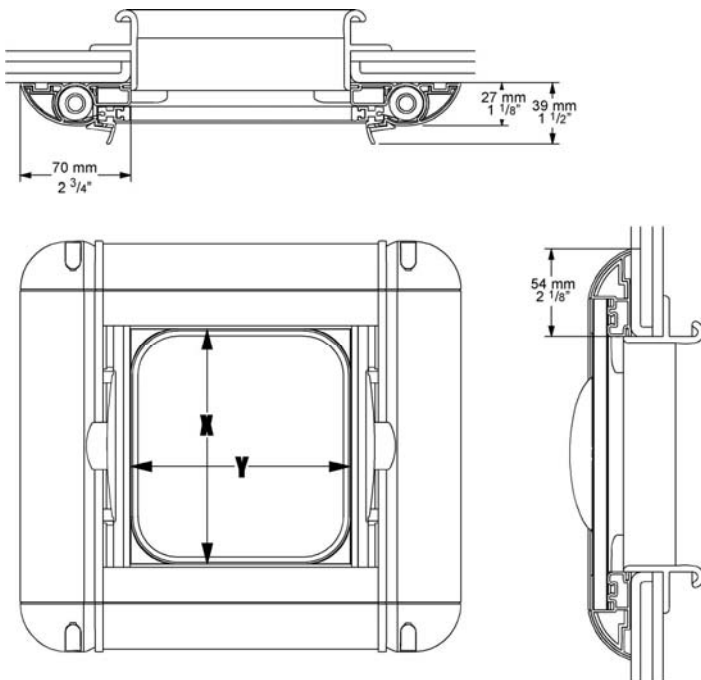

### Version 3 – PVCliner

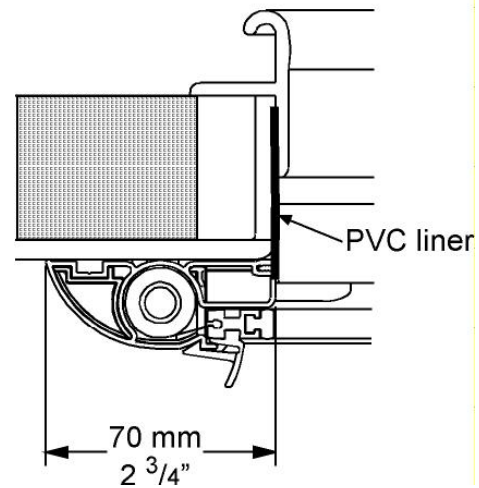

See Technical Sheet 26 for Round Hatches

## Description

- Low profile surface mounted plastic SKYscreen with integrated liner option and matching hatch radii

## Install Design Points

- Sizing: Maximum size: Width 700mm (27 1/2") (X) and Drop 700mm (27 1/2") (Y).
- Simple to install: four corner fixings, supplied complete with screws (4 x No 8 pan head)
- Available in three versions: (1) without corner radii; (2) with corner radii, no liner; (3) with corner radii and PVC liner
- Two optional liner heights – 63mm and 119mm (2 1/2" and 4 3/4")
- Three optional corner radii – 30mm/42mm/50mm (1 1/4", 1 5/8", 2") to suit, for example, Lewmar, Bomar, Taylor, Gebo, Hood, Mainship, and Goiot hatches.

## How to Order

- To order use custom order form
- When ordering select version – 1, 2 or 3 – and state hatch make and model
- Dimensions X, Y refer to the hatch cut out size.
- Blinds over 750mm have two handles

## Technical Specification

- Polymer extrusion, ultraviolet stabilised
- Stainless steel recoil springs
- Frame colour Off White RAL 9010 or Beige RAL 1013
- Matching colour mouldings UV Acetal
- Glass fibre PVC coated flyscreen mesh – white
- Off-white polyester blackout water repellent fabric
- PVCliner (if ordered) RAL No 9016
- Nylon brush strip

Oceanair Marine Limited Chichester PO20 0AY England

t: +44 (0)1243 606909 f: +44 (0)1243 608300 www.oceanair.co.uk e: TechSupport@oceanair.co.uk